

# Detector Processor Software

J. O. Goldsten

The Johns Hopkins University

Applied Physics Laboratory

Laurel, MD 20723-6099

Tel: (301) 953-5000 x8432

Fax: (301) 953-1093

E-Mail: [John\\_Goldsten@jhuapl.edu](mailto:John_Goldsten@jhuapl.edu)

## Detector Processor

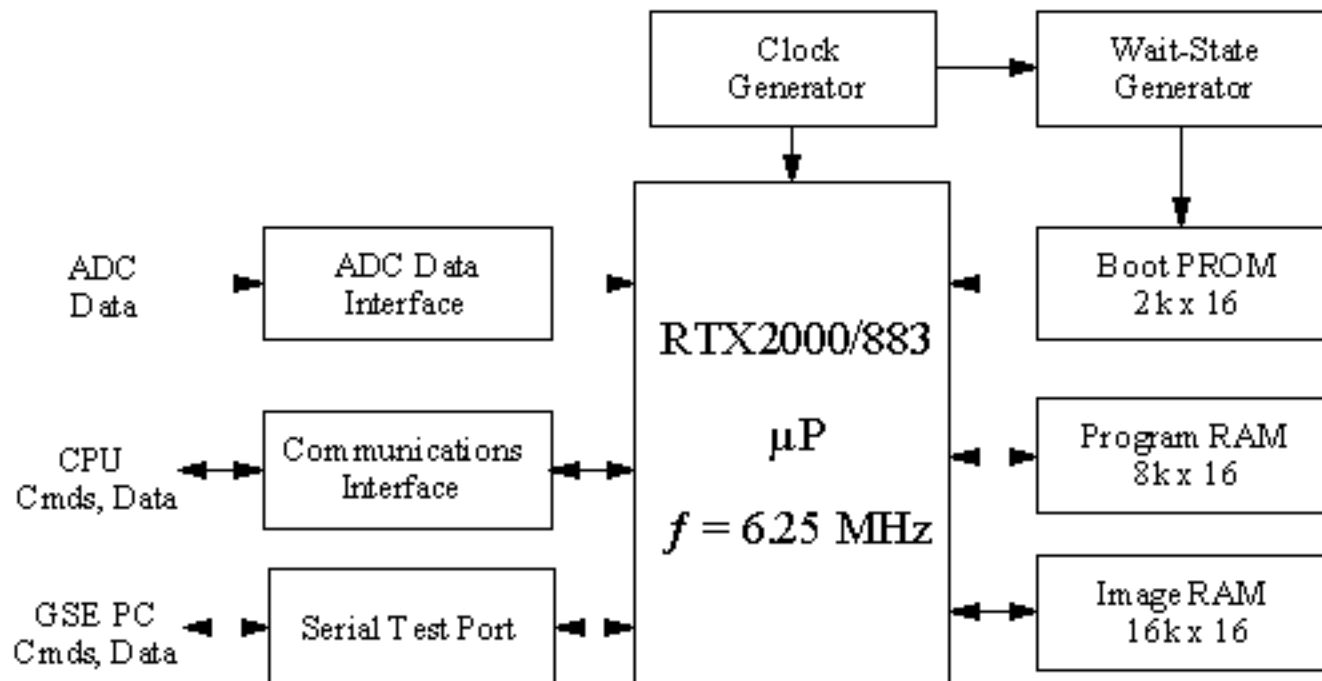

## UV Detector - Focal Plane

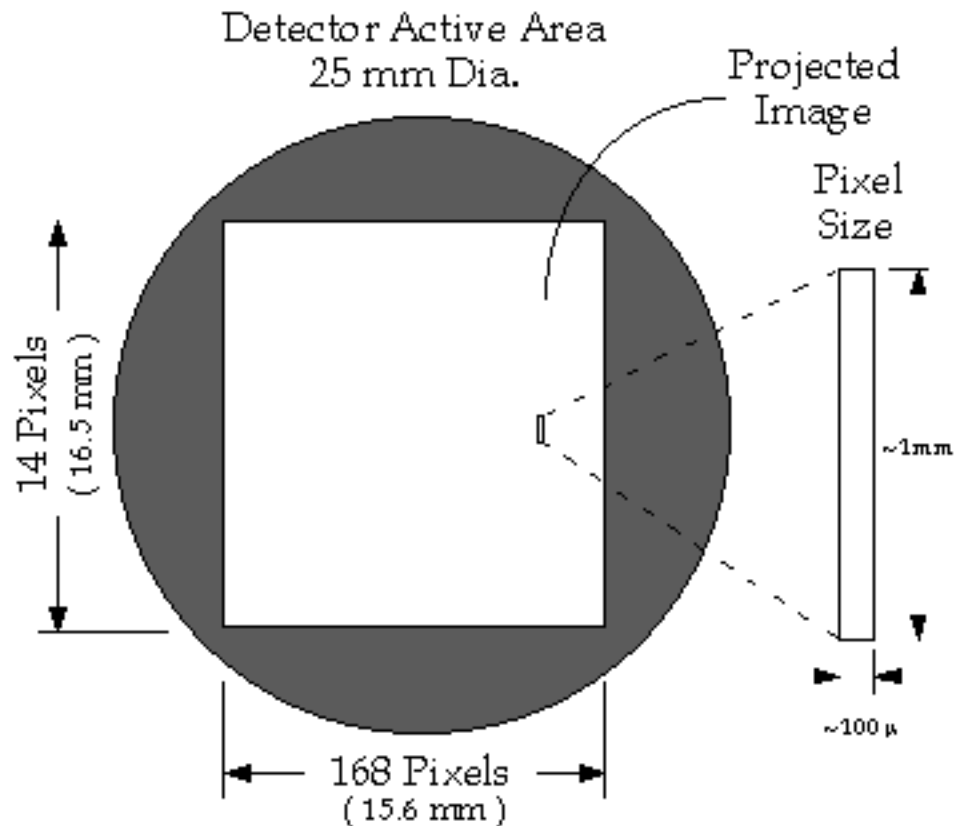

## Detector Data Processing

Poll for new event

Read W, S, I A/D values, check bounds

Compute x-y position

$$\text{Spectral coordinate} = \frac{aW}{W+S+2I} - \text{offset}$$

$$\text{Spatial coordinate} = \frac{bS}{W+S+2I} - \text{offset}$$

Quantize Results

8-bit Spectral

4-bit Spatial

Increment Corresponding Memory Bin

## Focal Plane Image Accumulation

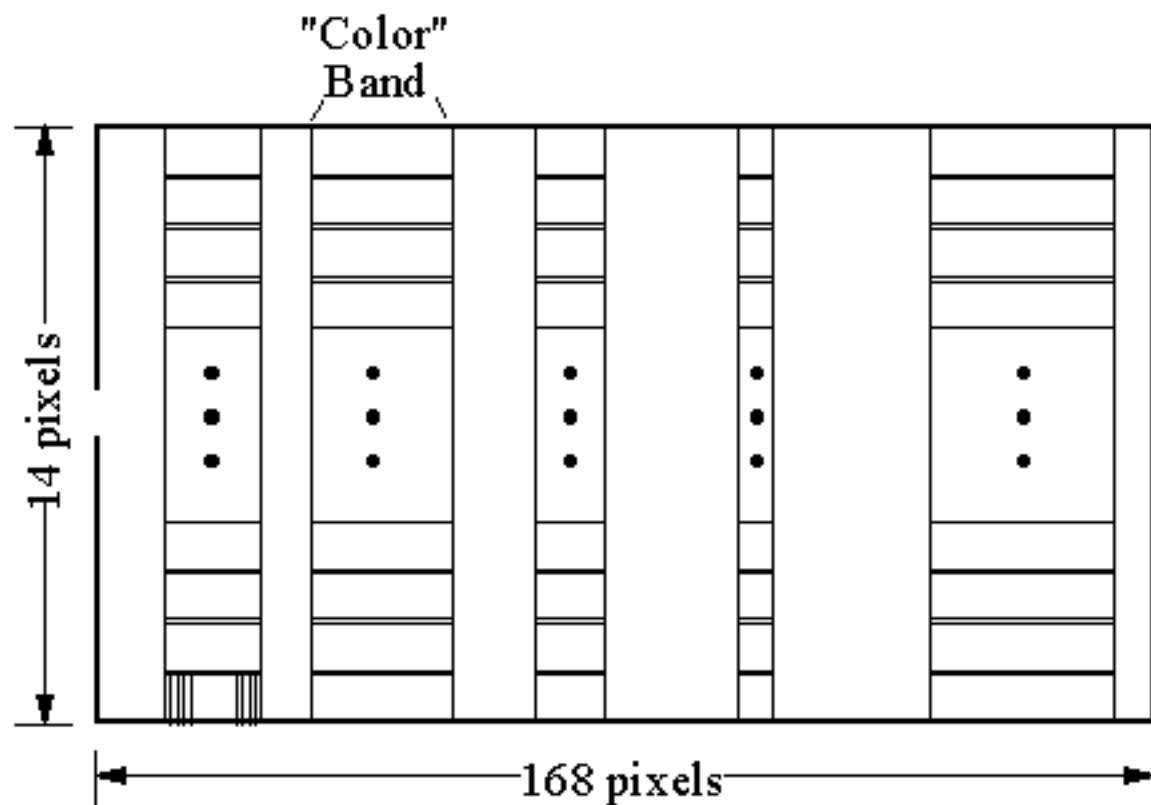

## DPU Commands

- PROM Based Commands:
  - Download from CPU to DPU RAM
  - Upload DPU memory to CPU
  - Run PROM test
  - Run RAM test
- RAM Based Commands:
  - Initialize DPU
  - Process Detector Data

## DPU Commands (Test Port Only)

- **PROM Based Commands:**
  - Download Code - OLS format
  - Dump Memory
  - Alter Memory
  - Dump Registers
  - Print Stack
  - Push data onto Stack
  - Go to program
  - Emit data to test port

## Task Level Descriptions

### **Download Code**

- Inputs: Starting address location followed by sequential code or data.
- Outputs: None.
- Function: This PROM based routine reads data from the CPU via the communications bus and stores the data into DPU RAM. The first data element is used as a starting address in DPU



## Task Level Descriptions (cont.)

### **Upload Code**

- Inputs: Specified DPU address.
- Outputs: Contents of specified DPU address.
- Function: This PROM based routine reads a single specified address from the CPU and returns the contents of that address (code or data) to the CPU. The DPU will then wait for either a new

## Task Level Descriptions (cont.)

### **DPU PROM Checksum Test**

- Inputs: None.
- Outputs: Completion code.
- Function: This PROM based routine performs a simple checksum test on the DPU PROM. An error or completion code is returned. The DPU then returns to the main monitor loop.

## Task Level Descriptions (cont.)

### **DPU RAM Test**

- Inputs: None.
- Outputs: Completion code.
- Function: This PROM based routine checks every memory location in DPU RAM. The test does not preserve previously stored data. The DPU returns an error or completion code before returning to the main monitor loop.

## Task Level Descriptions (cont.)

### **Initialize DPU**

- Inputs: FPE Configuration values.
- Outputs: Completion code.
- Function: This task readies the DPU for Detector data processing. The task is comprised of the following subtasks.  
Write all hardware configuration values to the appropriate hardware control registers. Initialize all variables and arrays. Build the

## Task Level Descriptions (cont.)

### **Process Detector Data**

- Inputs: None.
- Outputs: 2-D Image Accumulation (via transfer commands)
  - Data Structure: 12-bit index = 4-bit spatial position ; 8-bit spectral bin location
- Function: Core dedicated function of the DPU. Poll A/D Board for event. When new event present, read W, S, and I values. Reject event if any of the three values are

## Task Level Descriptions (cont.)

### **Transfer data - Imaging Mode**

- Inputs: Color Table, 2-D Image accumulation.
- Outputs: For each spatial position, outputs the co-added value for each of the five colors as defined by the color table.
- Function: For each spatial position, sum spectral bins as defined in color table for each color. Color table contains length

## Task Level Descriptions (cont.)

### **Transfer data - Spectrograph Mode**

- Inputs: Focal Plane Segment Selection, 2-D Image accumulation.
- Outputs: For each spatial position within chosen focal plane segment, outputs all 160 spectral bin values.
- Function: Begin at segment start position. Transfer 160 spectral bin values. Repeat for each spatial index within

## Task Level Descriptions (cont.)

### **Transfer data - Pixel Mode**

- Inputs: Pixel address, 2-D Image accumulation.
- Outputs: Individual pixel values.
- Function: Read specified absolute address from TLM processor. Transfer pixel value. Wait for new address or reset.



## Task Level Descriptions (cont.)

### **Transfer data - W, S, I values**

- Inputs: None.
- Outputs: W, S, I values.
- Function: This task collects and transfers raw Wedge, Strip, and Intermediate anode values to the TLM processor. Poll the A/D Board. When new event present, read in three A/D values and transfer data to TLM processor. Return to

